

HD 070V



OSCILLATION



Tandem roller with oscillation and vibration

- ▶ Ergonomic driver's seat with 2 multifunction control levers
- ▶ Driver's seat including steering wheel and instrument panel rotatable and pivotable
- ▶ Outstanding visibility to the surface and edges of the drums and surroundings
- ▶ Crab steering to extend the working width
- ▶ Universally applicable due to oscillation and vibration
- ▶ Hydrostatic all-wheel drive ensures great climbing pave
- ▶ Turbo-Diesel with high performance and low noise level
- ▶ Sprinkler system with 2 water pumps, spraying jets visible from the driver's seat



TECHNICAL DATA

HD 070V ASC

Weights	
Operating weight	kg 7705
Maximum weight	kg 10300
Axle load, front/rear	kg 3835/3870
Static linear load, front/rear	kg/cm 25,6/25,8
Machine dimensions	
Max. working width	mm 1600
Turning radius, inside	mm 4174
Diesel engine	
Manufacturer	DEUTZ
Type	TD 2011 L04 W
Number of cylinders	4
Power rat. ISO 14396, kW/PS/rpm	63,0/85,7/2500
Power rating SAE J1349, kW/HP/rpm	63,0/84,4/2500
Drive	
Hydrostatic drive, front/rear	Hydr. motor/hydr. motor
Speed, transportation gear	km/h 0-10,5
Climbing ability, vibration on/off	% 25/30
Vibration system	
Hydrostatic drive. Oscillator and/or vibrator separately switchable. Engine independent automatic frequency control with digital display. Oscillation and vibration manually and automatically switchable.	
Vibration	
Vibration frequency, front, I/II	Hz 42/50
Amplitude, front, I/II	mm 0,55/0,38
Centrifugal force, front, I/II	kN 63/62
Oscillation	
Oscillation frequency, rear, I/II	Hz 30/36
Tangential amplitude, rear, I/II	mm 1,34/1,34
Oscillation force, rear, I/II	kN 72/103
Steering	
Steering, type	Pivoted steering
Steering, actuation	hydrostatic, steer. wheel
Steering lock +/-	Grad 36
Oscillation angle +/-	Grad 10
Brake system	
Service brake, mode of action	hydrostatic
Service brake, actuation	Drive lever
Parking brake, mode of action	Spring-loaded/mechanical
Parking brake, actuation	electr. a. autom.
Emergency brake, mode of action	hydr./mech.
Emergency brake, actuation	Emergency stop
Sprinkler system	
Water sprinkler, type	Pressure
Actuation, sprinkling	interval/manual
Water tank, capacity	Ltr. 720
Equipment	
Spring loaded driving position, 1 swivelling and turning driver seat, 2 multifunctional levers, left and right at seat. Indicators for: engine temperature, working hours, fuel tank, control lights and emergency stop button. 2 working lights rear, main battery switch, triple oil filter. Indicators for: hydraulic oil temperature, water level in tanks. CE prepared.	
Optional	
Panoramic ROPS cabin with: heating, dust-free ventilation, sun shade, interior lighting, front and rear wipers, interior mirror, beacon, ROPS/FOPS, HCQ-Indicator Asphalt, safety belt, speedometer, sound isolation, sun top, pressing and cutting equipment, radio, special paint, sponge roll, bitumen-temperature gauge, back-up alarm.	

HD 070V ASC - Tandem roller with oscillation and vibration

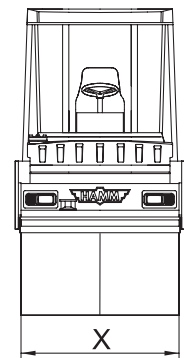
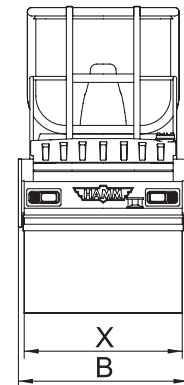
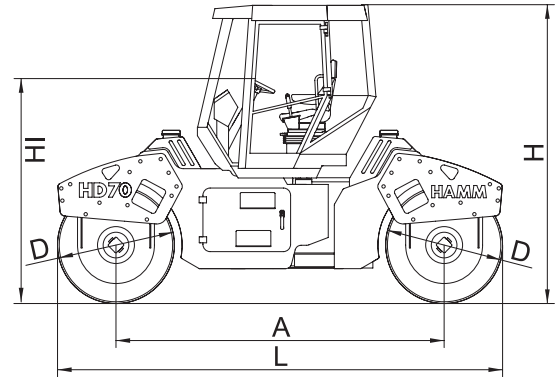

Further data on request / subject to change

		HD 070V ASC
Total length	L	4340
Width	B	1610
Total height	H	2940
Wheel base	A	3200
Roller drum width	X	1500
Drum diameter	D	1140
Height loading, min.	HI	2260